

migra SC/MC ModbusRTU

Large Format, Graphics Compatible Display with ModbusRTU Interface

User's Manual



migra SC/MC ModbusRTU

Large Format, Graphics Compatible Display with ModbusRTU Interface

Index

1	GENERAL	3
2	SYSTEM OVERVIEW	3
3	MODBUSRTU INTERFACE	4
3.1	Display Control Via ModbusRTU	5
3.2	Example	7
3.3	Connector Pin Assignments	8
3.3.1	External Connections	8
3.3.2	Internal LEDs and Switches	10
4	VERSIONS OVERVIEW	13

migra SC/MC ModbusRTU

Large Format, Graphics Compatible Display with ModbusRTU Interface

1 General

This display is based on the „migra SC/MC Serial“, which is expanded by a ModbusRTU interface.

The interface is used for the connection to a ModbusRTU controller (PLC) at one side and the data exchange (RS485 frames) to the display at the other side.

The frames for the display correspond to those of the „serial MIGRA“ and are described in the **User’s Manual „migra SC/MC Serial“**.

2 System Overview

The display is controlled with a ModbusRTU interface.

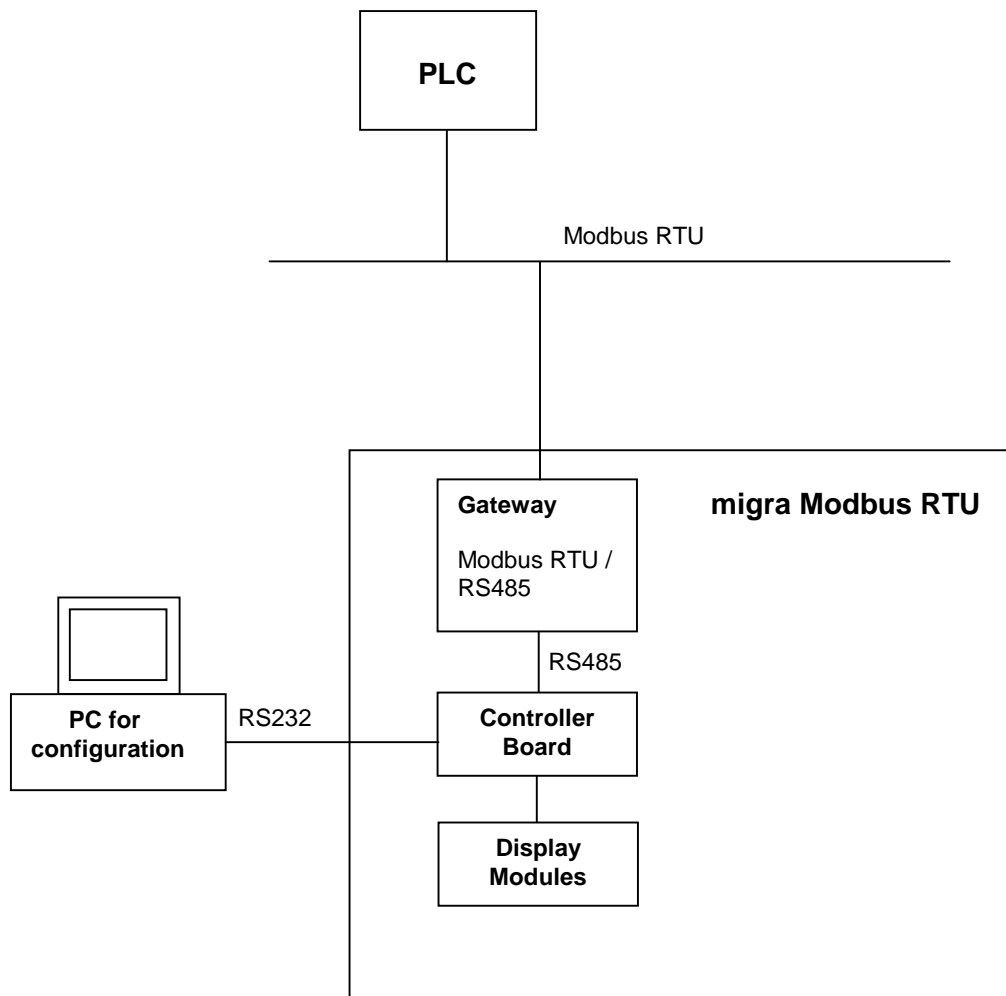

migra SC/MC ModbusRTU

Large Format, Graphics Compatible Display with ModbusRTU Interface

3 ModbusRTU Interface

The internal interface is the „ Modbus RTU Serial Gateway“ of the company HMS (AB7010). At the enclosed compact disc you can find the documentation. Alternatively, you can find the files at the home page of HMS (www.anybus.com).

migra SC/MC ModbusRTU

Large Format, Graphics Compatible Display with ModbusRTU Interface

3.1 Display Control Via ModbusRTU

The display represents a ModbusRTU-Slave and is controlled by a ModbusRTU-Master (f.e. a PLC).

To change the display contents, the ModbusRTU-Master has to write to some Registers. Therefore the commands "Force Multiple Registers" (function code $16_d=10_H$) or "Read/Write Registers" (function code $23_d=17_H$) can be used.

Here we assume that "Registers" are counted beginning at "0". If your PLC starts counting at "1" you may have to increase the register-address by 1!

The frames, which are described in the user's manual „migra SC/MC Serial“ („02 81 80 8X DATA-Unit 03“), must be entered in the **ModbusRTU output data** as follows:

Register (Output)	HMS memory address	Contents	Description
0400 _H HIGH	200 _H	0	Control register HIGH: static 0(don't change)!
LOW	201 _H	0	Control register LOW: static 0(don't change)!
0401 _H HIGH	202 _H	XX	Trigger byte: The transmission of the frame is executed with an increasing by one
LOW	203 _H	6... n+5	Length byte: frame length
0402 _H HIGH	204 _H	02 _H	MIGRA frame „STX“ (static)
LOW	205 _H	81 _H	MIGRA frame „DA“ (destination address)
0403 _H HIGH	206 _H	80 _H	MIGRA frame „SA“ (static)
LOW	207 _H	80 _H or 81 _H	MIGRA frame „FC“: 0x80 = „without response“, 0x81 = „with response“
0404 _H HIGH	208 _H	XX	MIGRA frame „Data unit, 1 st Byte“
LOW	209 _H	XX	MIGRA frame „Data unit, 2 nd Byte“
0405 _H HIGH	20A _H	XX	MIGRA frame „Data unit, 3 rd Byte“
LOW	...	XX	...
... HIGH	208 _H + (n-1)	XX	MIGRA frame „Data unit, n th Byte“
... LOW	208 _H + n	03 _H	MIGRA frame „ETX“ (static)

The length byte and the MIGRA frame must be entered first. Then, the trigger byte must be increased by one.

Thereby, the entered frame is transmitted to the MIGRA.

If the controlling happens without response frame („FC“ = 80_H), the respectively next frame must be sent approx. 100 to 200 ms soonest!

If you use the response („FC“ = 81_H), the respectively next frame may be sent immediately after receiving the response!

migra SC/MC ModbusRTU

Large Format, Graphics Compatible Display with ModbusRTU Interface

A possible response appears in the **Modbus RTU input data**:

Register (Input)	HMS memory address	Contents	Description
0000 _H HIGH	000 _H	0x9F	Status register HIGH: without meaning!
LOW	001 _H	0	Status register LOW: without meaning!
0001 _H HIGH	002 _H	XX	Trigger byte: Is increased by 1 value after the reception of every response frame
LOW	003 _H	n+5	Length byte: response length
0002 _H HIGH	004 _H	02 _H	MIGRA response „STX“ (static)
LOW	005 _H	80 _H	MIGRA response „DA“ (static)
0003 _H HIGH	006 _H	81 _H	MIGRA response „SA“ (source address)
LOW	007 _H	80 _H	MIGRA response „FC“ (static)
0004 _H HIGH	008 _H	XX	MIGRA response „Data unit, 1 st Byte“
LOW	009 _H	XX	MIGRA response „Data unit, 2 nd Byte“
0005 _H HIGH	00A _H	XX	MIGRA response „Data unit, 3 rd Byte“
LOW	...	XX	...
... HIGH	008 _H + (n-1)	XX	MIGRA response „Data unit, n th Byte“
... LOW	08 _H + n	03 _H	MIGRA response „ETX“ (static)

The “Data unit” usually consists only of one byte (30_H).

Note:

In most cases, you do not need the response frame!

The necessary frame intervals, which depend on the effort for the evaluation, can also be found by trying (200 ms is OK for most applications).

migra SC/MC ModbusRTU

Large Format, Graphics Compatible Display with ModbusRTU Interface

3.2 Example

The online text „microSYST“ shall be shown at the display (without response):

ModbusRTU Output Data:

Register (Output)	HMS memory address	Contents	Description
0400 _H HIGH	200 _H	0	Control register HIGH: static 0(don't change)!
LOW	201 _H	0	Control register LOW: static 0(don't change)!
0401 _H HIGH	202 _H	x ↓ x+1	Trigger byte: The transmission of the frame is executed with an increasing by one (after the entries in HMS memory address 203 _H ... 211 _H have been done!)
LOW	203 _H	14	Length byte: frame length
0402 _H HIGH	204 _H	02 _H	MIGRA frame „STX“ (static)
LOW	205 _H	81 _H	MIGRA frame „DA“ (destination address)
0403 _H HIGH	206 _H	80 _H	MIGRA frame „SA“ (static)
LOW	207 _H	80 _H	MIGRA frame „FC“ (without response)
0404 _H HIGH	208 _H	6D _H	= 'm'
LOW	209 _H	69 _H	= 'i'
0405 _H HIGH	20A _H	63 _H	= 'c'
LOW	20B _H	72 _H	= 'r'
0406 _H HIGH	20C _H	6F _H	= 'o'
LOW	20D _H	53 _H	= 'S'
0407 _H HIGH	20E _H	59 _H	= 'Y'
LOW	20F _H	53 _H	= 'S'
0408 _H HIGH	210 _H	54 _H	= 'T'
LOW	211 _H	03 _H	MIGRA frame „ETX“ (static)

migra SC/MC ModbusRTU

Large Format, Graphics Compatible Display with ModbusRTU Interface

3.3 Connector Pin Assignments

3.3.1 External Connections

9pol. Sub-D Female Connector “ModbusRTU”

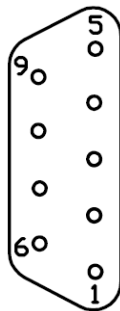

Pin	Assignment
1	
2	RS-232 TxD
3	RS-232 RxD
4	
5	GND Bus
6	+5V Bus Out
7	RS-485 D0 (Rx/Tx-)
8	RS-485 D1 (Rx/Tx+)
9	

Remark: Depending on DIP5 of the ModbusRTU-interface (see below) **either** the RS232-pins **or** the RS485-pins may be used. The unused pins have to be left open. Do **not** use a standard RS232-cable where **all** pins are connected. Otherwise the ModbusRTU-interface may be destroyed!!!

9pol. Sub-D Male Connector “RS232 migra”

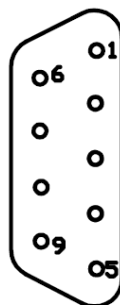

Pin	Assignment
1	
2	RxD
3	TxD
4	
5	GND
6	
7	
8	
9	

This connector serves for the configuration of the migra display.

migra SC/MC ModbusRTU

Large Format, Graphics Compatible Display with ModbusRTU Interface

Connector “Modbus Config”

Remark: This connector should not be used by the customer! The configuration is already done by microSYST and must not be changed! Otherwise the correct function of the display can not be guaranteed!

7pol. Mains Plug (230 VAC)

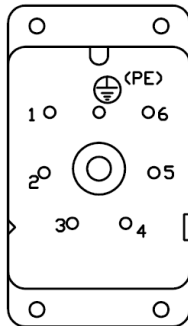

Pin	Assignment
1	L1
2	N
⊕ (PE)	PE

migra SC/MC ModbusRTU

Large Format, Graphics Compatible Display with ModbusRTU Interface

3.3.2 Internal LEDs and Switches

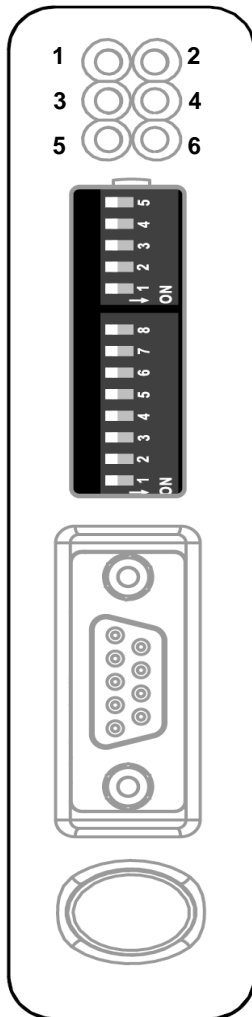

LED	State	Description
1 - Bus Error	Off	Normal operation
	Red	Bus error; CRC mismatch >10%
2 - Bus Ready	Off	Not powered
	Green	Normal operation (bus ready)
3 - Processing	Red	Bus is off line (bus not ready)
	Off	Currently not processing query
4 - HW Settings	Green, flashing	Currently processing query
	Off	Normal operation
5 - Subnet Status	Red	Not configured
	Off	Power off
	Green, flashing	Initializing and not running
	Green	Running
6 - Device Status	Red	Stopped or subnet error, or timeout
	Off	Power off
	Alternating Red/Green	Invalid or missing configuration
	Green	Initializing
	Green, flashing	Configuration OK

migra SC/MC ModbusRTU

Large Format, Graphics Compatible Display with ModbusRTU Interface

ModbusRTU Node Address

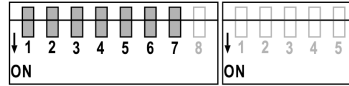

Node Address	DIP1	DIP2	DIP3	DIP4	DIP5	DIP6	DIP7
(reserved)	OFF	OFF	OFF	OFF	OFF	OFF	OFF
* 1	OFF	OFF	OFF	OFF	OFF	OFF	ON
2	OFF	OFF	OFF	OFF	OFF	ON	OFF
...
126	ON	ON	ON	ON	ON	ON	OFF
127	ON	ON	ON	ON	ON	ON	ON

* = Factory-Setting

ModbusRTU Baudrate

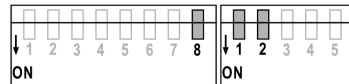

Baudrate	DIP8	DIP1	DIP2
(reserved)	OFF	OFF	OFF
1200 baud	OFF	OFF	ON
2400 baud	OFF	ON	OFF
4800 baud	OFF	ON	ON
9600 baud	ON	OFF	OFF
* 19200 baud	ON	OFF	ON
38400 baud	ON	ON	OFF
57600 baud	ON	ON	ON

* = Factory-Setting

ModbusRTU Parity & Stop Bits

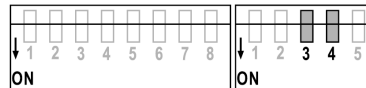

Parity	DIP3	DIP4
(reserved)	OFF	OFF
* No parity, 2 stop bits	OFF	ON
Even parity, 1 stop bit	ON	OFF
Odd parity, 1 stop bit	ON	ON

* = Factory-Setting

ModbusRTU Physical Interface

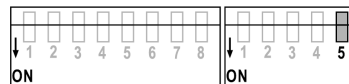

Interface Type	DIP5
RS232	ON
* RS485	OFF

* = Factory-Setting

migra SC/MC ModbusRTU

Large Format, Graphics Compatible Display with ModbusRTU Interface

Important note:

To change the setting of the DIP-switches obey the following order:

- disconnect the power supply
- open the housing
- open the dip switch protection cap (carefully - using a little screw driver)
- set the dip switches as desired
- close the dip switch protection cap
- close the housing
- reconnect the power supply

While the housing is open power may only be applied by qualified personnel and nothing has to be touched inside the housing at this time! Otherwise electrical shock and danger to life may happen! Please be careful!

migra SC/MC ModbusRTU

Large Format, Graphics Compatible Display with ModbusRTU Interface

4 Versions Overview

Version	Date	Remark, Description
1.00	29.06.08	Kreuzer, Nickl: Document created
1.10	16.08.10	SC/MC 5/3 -> SC/MC

Certified per **DIN EN ISO 9001:2008**.