

migan ModbusRTU

Large Display Numeric LED with Modbus RTU Interface

User Manual



migan ModbusRTU

Large Display Numeric LED with Modbus RTU Interface

Index

1	GENERAL	3
2	SYSTEM OVERVIEW	3
2.1	Device Configuration	4
3	TECHNICAL INFORMATION	5
3.1	Overall Specification	5
3.2	Device Start-Up	6
3.3	Display Control Via ModbusRTU	7
3.4	Connector Pin Assignments	10
3.4.1	External Connections	10
3.4.2	Internal LEDs and Switches	11
4	APPENDIX	14
4.1	Displayable Characters	14
4.2	Maintenance and Care	15
4.3	Declaration of Conformity	16
4.4	Guarantee	17
4.5	Versions Overview	18

migan ModbusRTU

Large Display Numeric LED with Modbus RTU Interface

1 General

The large format numeric display can be used universally as a production display unit or as an information board. The modular design allows for cost-effective models of various sizes, and with different character heights and numbers of digits. Thus integration into existing equipment or systems is easy and simple.

2 System Overview

The display is controlled with a ModbusRTU interface.

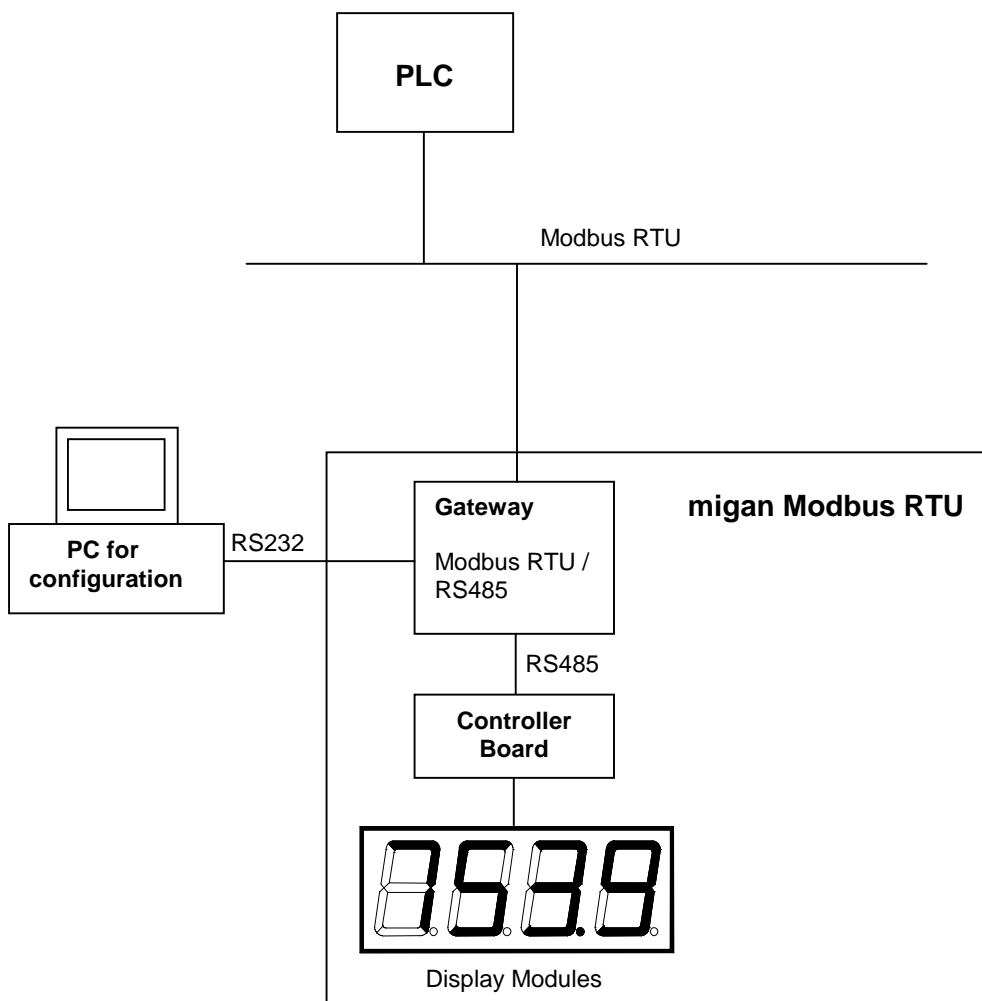

migan ModbusRTU

Large Display Numeric LED with Modbus RTU Interface

2.1 Device Configuration

Type:

for inside use for outside use

Character height:

60 mm 75 mm 100 mm 120 mm 150 mm 180 mm
 200 mm 250 mm

Number of lines: _____ **Number of digits per line:** _____

Display colour:

red green yellow white blue

View:

single sided double sided four sided

Operating voltage:

230 VAC / 50 Hz 110 VAC / 60 Hz 24 VDC

Protection:

IP40 IP54 IP65 IP _____

Operating temperature:

0 to +50 °C -25 to +50 °C _____ °C

Housing dimensions: _____ x _____ x _____ mm

Housing Material:

Aluminum profile Stainless steel Sheet metal

Device address: _____

migan ModbusRTU

Large Display Numeric LED with Modbus RTU Interface

3 Technical Information

3.1 Overall Specification

	migan for indoor use	migan for outdoor use
Display type	7 segment LED	7 segment LED, 16x16 pixels per module <u>pixel size:</u> up to 180 mm: 5.2 x 3.8 mm (oval) at 250 mm: 5 mm (round)
Angle of radiation	n/a	up to 180 mm: 110°/50° (hori z./vert.) at 250 mm: 30° (horiz./vert.)
Character height	60 / 100 / 150 / 200 / 250 mm	75 / 120 / 180 / 250 mm
Digits	1 to 15	2 to 16 (2 digits per module)
Number of lines	standard 1 line, multiple lines on request	at 75 mm: 2 lines per module, from 120 mm: 1 line per module, multiple lines on request
Display colour	Red	standard red, optional green, yellow, white and blue
Light intensity	n/a	red > 3100 cd/m ² , green > 3720 cd/m ² , yellow > 3000 cd/m ² , white > 4000 cd/m ² , blue > 2000 cd/m ²
Brightness control	n/a	automatically in 100 levels
Operating voltage	230 VAC / 50 Hz, 110 VAC / 60 Hz or 24 VDC ±20%	
View	single sided to four sided	single sided or double sided
Interface	ModbusRTU	
Displayable characters	see corresponding chapter	
Labelling	upon request	
Housing	industrial version, powder coated aluminum	
Housing colour	RAL 7016 (anthracite)	
Mounting	articulated arm, angle bracket or mounting frame	
Protection	IP54 or IP65	IP65 for outdoor use
Operating temp.	0...+50 °C	-20...+50 °C
Storage temperature	-25...+70 °C	

migan ModbusRTU

Large Display Numeric LED with Modbus RTU Interface

3.2 Device Start-Up

Internal memory and function tests are performed at the large format display during power-up.

The following parameters appear:

- Baud rate
- Parity
- Internal Address

These parameters do **not** have a meaning for the user and serve merely for diagnostic purposes of the **internal** RS485 interface.

The ModbusRTU communication parameters are set via DIP-switches inside the housing (see below) and will **not** be displayed!

migan ModbusRTU

Large Display Numeric LED with Modbus RTU Interface

3.3 Display Control Via ModbusRTU

The display represents a ModbusRTU-Slave and is controlled by a ModbusRTU-Master (f.e. a PLC).

To change the display contents, the ModbusRTU-Master has to write to some Registers. Therefore the commands “Force Multiple Registers” (function code $16_d=10_H$) or “Read/Write Registers” (function code $23_d=17_H$) can be used.

Here we assume that “Registers” are counted beginning at “0”. If your PLC starts counting at “1” you may have to increase the register-address by 1!

The following data has to be written **starting at register-address 0402_H**:

Register	Contents
0402 _H HIGH	P1 = decimal point byte 1 (for digits 1...5)
LOW	P2 = decimal point byte 2 (for digits 6...10)
0403 _H HIGH	P3 = decimal point byte 3 (for digits 11...15)
LOW	D1 = ASCII-code for digit 1
0404 _H HIGH	D2 = ASCII-code for digit 2
LOW	D3 = ASCII-code for digit 3
0405 _H HIGH	D4 = ASCII-code for digit 4
LOW	D5 = ASCII-code for digit 5
0406 _H HIGH	D6 = ASCII-code for digit 6
LOW	D7 = ASCII-code for digit 7
0407 _H HIGH	D8 = ASCII-code for digit 8
LOW	D9 = ASCII-code for digit 9
0408 _H HIGH	D10 = ASCII-code for digit 10
LOW	D11 = ASCII-code for digit 11
0409 _H HIGH	D12 = ASCII-code for digit 12
LOW	D13 = ASCII-code for digit 13
040A _H HIGH	D14 = ASCII-code for digit 14
LOW	D15 = ASCII-code for digit 15

Remarks:

- Up to 15 digits are possible!
- It is not necessary to initialize unused digits!
- Registers 402_H...40A_H correspond to the “output data area” 204_H...215_H of the used “HMS Anybus Communicator for Modbus RTU”.

migan ModbusRTU

Large Display Numeric LED with Modbus RTU Interface

Display Data Positioning:

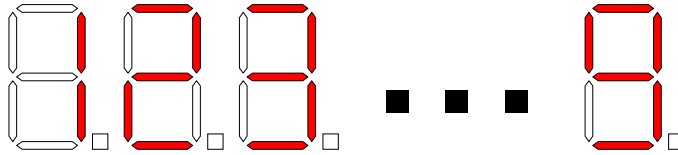

D1 is the 1st digit from the left side of the display.

...

Dn is the nth digit from the left side of the display (n=2...15).

Decimal Point Bytes:

If a decimal point needs to be set, the corresponding bit must be 1.

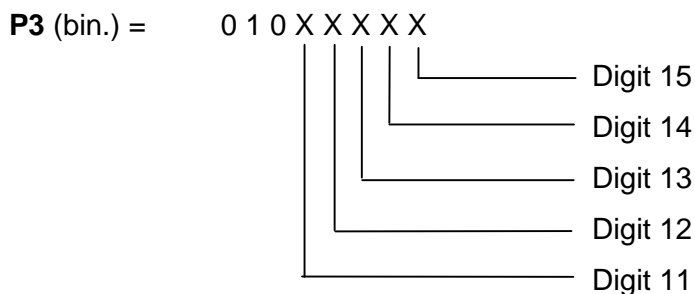
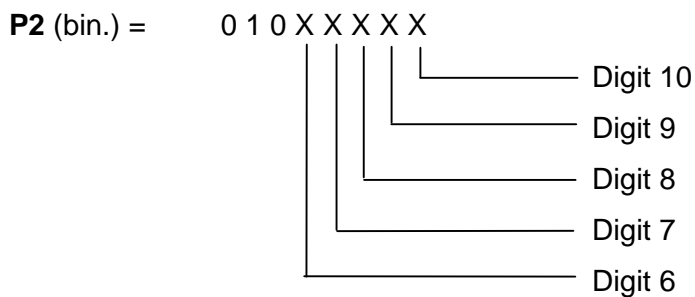
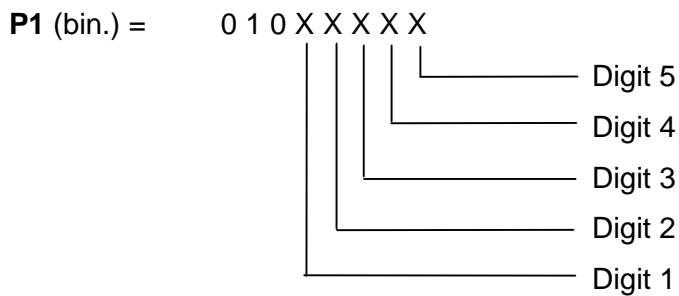

So - if no decimal point needs to be set P1, P2 and P3 contain 40_H each!

migan ModbusRTU

Large Display Numeric LED with Modbus RTU Interface

Example for a ModbusRTU-Telegram="Request" (in hex):

```
01
17
04 02 00 08 04 02 00 08 10
55 5F 5F 31 32 33 34 35 36 37 38 39 30 31 32 33
FC F8
```

01 : ModbusRTU node address

17 : ModbusRTU function code for "Read/Write Registers"

04 02 00 08 04 02 00 08 10 : Read/Write 8 Registers starting at 0402_H

55 5F 5F 31 32 33 34 35 36 37 38 39 30 31 32 33 :
New Display Data = - all points set except at digit 2 and 4
- display "12345..."

FC F8 = CRC16(FFFF_H)-Checksum

Remark: The ModbusRTU communication normally is done automatically by the PLC! The user just has to set up the destination register addresses and the "data part" of the telegram (point bytes and digit data)!

migan ModbusRTU

Large Display Numeric LED with Modbus RTU Interface

3.4 Connector Pin Assignments

3.4.1 External Connections

9pol. Sub-D Female Connector “ModbusRTU”

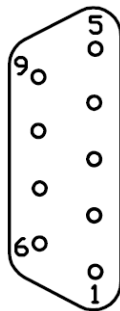

Pin	Assignment
1	
2	RS-232 TxD
3	RS-232 RxD
4	
5	GND Bus
6	+5V Bus Out
7	RS-485 D0 (Rx/Tx-)
8	RS-485 D1 (Rx/Tx+)
9	

Remark: Depending on DIP5 of the ModbusRTU-interface (see below) **either** the RS232-pins **or** the RS485-pins may be used. The unused pins have to be left open. Do **not** use a standard RS232-cable where **all** pins are connected. Otherwise the ModbusRTU-interface may be destroyed!!!

9pol. Sub-D Male Connector “Configuration, RS232”

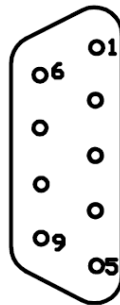

Pin	Assignment
1	
2	RxD
3	TxD
4	
5	GND
6	
7	
8	
9	

Remark: This connector should not be used by the customer! The configuration is already done by microSYST and must not be changed! Otherwise the correct function of the display can not be guaranteed!

migan ModbusRTU

Large Display Numeric LED with Modbus RTU Interface

7pol. Mains Plug (230 VAC)

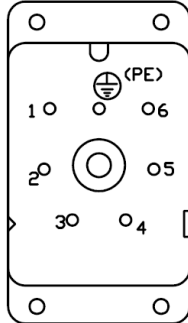

Pin	Assignment
1	L1
2	N
(PE)	PE

3.4.2 Internal LEDs and Switches

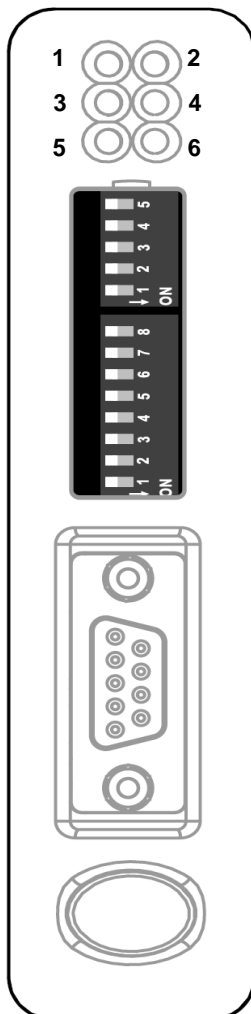

LED	State	Description
1 - Bus Error	Off	Normal operation
	Red	Bus error; CRC mismatch >10%
2 - Bus Ready	Off	Not powered
	Green	Normal operation (bus ready)
	Red	Bus is off line (bus not ready)
3 - Processing	Off	Currently not processing query
	Green, flashing	Currently processing query
4 - HW Settings	Off	Normal operation
	Red	Not configured
5 - Subnet Status	Off	Power off
	Green, flashing	Initializing and not running
	Green	Running
	Red	Stopped or subnet error, or timeout
6 - Device Status	Off	Power off
	Alternating Red/Green	Invalid or missing configuration
	Green	Initializing
	Green, flashing	Configuration OK

migan ModbusRTU

Large Display Numeric LED with Modbus RTU Interface

ModbusRTU Node Address

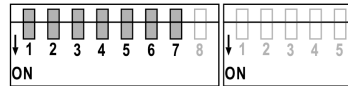

Node Address	DIP1	DIP2	DIP3	DIP4	DIP5	DIP6	DIP7
(reserved)	OFF	OFF	OFF	OFF	OFF	OFF	OFF
* 1	OFF	OFF	OFF	OFF	OFF	OFF	ON
2	OFF	OFF	OFF	OFF	OFF	ON	OFF
...
126	ON	ON	ON	ON	ON	ON	OFF
127	ON	ON	ON	ON	ON	ON	ON

* = Factory-Setting

ModbusRTU Baudrate

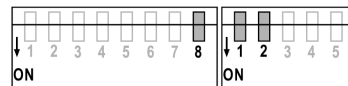

Baudrate	DIP8	DIP1	DIP2
(reserved)	OFF	OFF	OFF
1200 baud	OFF	OFF	ON
2400 baud	OFF	ON	OFF
4800 baud	OFF	ON	ON
9600 baud	ON	OFF	OFF
19200 baud	ON	OFF	ON
38400 baud	ON	ON	OFF
57600 baud	ON	ON	ON

ModbusRTU Parity & Stop Bits

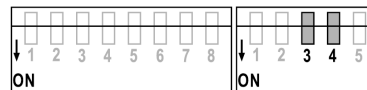

Parity	DIP3	DIP4
(reserved)	OFF	OFF
No parity, 2 stop bits	OFF	ON
Even parity, 1 stop bit	ON	OFF
Odd parity, 1 stop bit	ON	ON

ModbusRTU Physical Interface



Interface Type	DIP5
RS232	ON
* RS485	OFF

* = Factory-Setting

migan ModbusRTU

Large Display Numeric LED with Modbus RTU Interface

Important note:

To change the setting of the DIP-switches obey the following order:

- disconnect the power supply
- open the housing
- open the dip switch protection cap (carefully - using a little screw driver)
- set the dip switches as desired
- close the dip switch protection cap
- close the housing
- reconnect the power supply

While the housing is open power may only be applied by qualified personnel and nothing has to be touched inside the housing at this time! Otherwise electrical shock and danger to life may happen! Please be careful!

migan ModbusRTU

Large Display Numeric LED with Modbus RTU Interface

4 Appendix

4.1 Displayable Characters

The data bytes are ASCII coded.

<i>Lower</i> P	<i>Higher</i> P	0	1	2	3	4	5	6	7
0				"Blank"	0		P		P
1					1	A	9	A	9
2					2	b	7	b	7
3					3	c	5	c	5
4					4	d	F	d	F
5					5	E	U	E	U
6					6	F		F	
7					7	G		G	
8				C	8	H		H	
9				J	9	I	9	I	9
A						J		J	
B									
C						L		L	
D				-					
E						n		n	
F						o	-	o	

migan ModbusRTU

Large Display Numeric LED with Modbus RTU Interface

4.2 Maintenance and Care

Please observe the following instructions:

- Make sure that the housing can be opened for adjustment and maintenance even after the display has been installed. Allow for adequate clearance at the back, front and top of the display unit in order to allow for sufficient ventilation (if vent slots are included).
- Display quality is impaired by direct illumination with bright light sources and/or direct sunlight.
- The display must be switched off before cleaning.
- Protect the display from excessive humidity, extreme vibration, direct sunlight and extreme temperatures. Non-observance may lead to malfunctioning or destruction of the device. Under certain circumstances electrical shock, fire and explosion may occur as well. Information concerning allowable ambient conditions, including recommended temperature ranges, can be found in the chapter entitled "Technical Information".
- The display may not be placed into service if the device and/or the power cable are known to be damaged.
- Do not attempt to repair the device yourself. The guarantee is rendered null and void if the device is tampered with by unauthorised persons.

migan ModbusRTU

Large Display Numeric LED with Modbus RTU Interface

4.3 Declaration of Conformity

microSYST Systemelectronic GmbH, Zur Centralwerkstätte 10,
92637 Weiden, Germany

does hereby declare that the product described in this user's manual,

“migan”

to which this declaration makes due reference,
is in compliance with the following standards or normative documents:

Interference emission: generic standard EN 50081 - 2, issued July 1993
Product standard: EN 55011; group 1/2; class A, issued March 1991
Limit values identical to EN 55022

Interference immunity: generic standard EN 50082 - 2, issued March 1995
Basic specification per table

In accordance with regulations specified by guideline 89/336/ EWG (and
EMVG).

Weiden, 22 November 1999

microSYST Systemelectronic GmbH

migan ModbusRTU

Large Display Numeric LED with Modbus RTU Interface

4.4 Guarantee

The display is guaranteed for the duration specified in the “General Terms and Conditions” regarding manufactured products and services rendered for the electrical industry period against defects which existed at the time the device was delivered to the buyer.

The device is subject to technical change without notice. Errors and omissions are excepted. No claims can be honoured for the shipment of a new product. The buyer is required to make notification of defects within 2 weeks after identification of such. Non-observance of notification requirements is equated with acceptance of the defect.

Defects and their symptoms must be described as accurately as possible in order to allow for reproducibility and elimination. The buyer must provide for access to all required and/or useful information regarding defects at no charge, as well as to the affected devices, and must make all of the required data and machine time available free of charge.

The guarantee does not cover defects which result from non-observance of the prescribed conditions of use, or from improper handling.

If the device has been placed at the disposal of the buyer for test purposes and has been purchased subsequent to such testing, both parties agree that the product is to be considered “used” and that it has been purchased “as is”. No guarantee claims may be made in such cases.

The “General Terms and Conditions” regarding manufactured products and services rendered for the electrical industry apply as well.

migan ModbusRTU

Large Display Numeric LED with Modbus RTU Interface

4.5 Versions Overview

Version	Date	Remark, Description
1.00	29.11.07	Kreuzer: Document created
1.01	20.12.07	Nickl: Revised
1.10	31.01.11	migan AW added

Certified per **DIN EN ISO 9001:2008**.